

## Hall Effect in Lyotropic Liquid Crystals

HAMLET G. BADALYAN, STEPAN M. YAYLOYAN

Department of General Physics, Yerevan State University, 1 Alex Manoogian St.,  
Yerevan, 0025 Armenia

*It is known that Hall effect takes place in different media. The Hall effect is well studied in semiconductors. It is known quantum, quantum spin, the anomalous Hall effect, as well as the Hall effect in ionized gases. However, up to date, as evidenced from the review of scientific literature, the study of this effect in lyotropic liquid crystals (LLC) was given insufficient attention. In this paper the peculiarities of the Hall effect in the LLC were studied. It was shown that in liquid crystal systems Hall potential is approximately 100 times greater than in semiconductors. Also it was shown that after removal of the electric and magnetic fields, the Hall potential in LLC remained intact, decreasing over time, and periodically reversing its sign.*

**Keywords:** Hall effects, lyotropic liquid crystal, amphiphilic substance, Hall emf.

### Introduction

In conductors and semiconductors the simultaneous influence of the magnetic and electric fields causes a phenomenon that became known as the galvanomagnetic effect [1-4]. Among these phenomena are the *Hall*, *Nernst* (thermomagnetic), *Ettingshausen* (between metal plates in a magnetic field and in the presence of a thermal gradient) effects, etc. Since in conductors charge concentration is  $10^{12}$  times higher than in semiconductors and in Hall coefficient ( $R$ ) the value of  $n$  lies in the denominator, the potential difference (*Hall emf*) for semiconductors is quite large. *Hall emf*,  $V_x$ , of semiconductor materials is proportional to the magnetic field strength  $H$ , so we have  $V_x = f(H)$  [5-8]. This dependence of the liquid crystal is unique that the micelles play role of charge carriers, which concentration  $n$  is small but the charge is high and which move within the sample undergoing resistance from the medium. Studies show that it causes at least 100 times increase of the *Hall emf*.

Amphiphilic substance of certain concentration is mixed up with water, and the resulting homogeneous solution is poured into the "sandwich" type cell and tightly closed by both sides. The Lyotropic Liquid Crystals (LLC) thus obtained is left for one day in order the system moves to the equilibrium state [9, 10].

## Experimentation

In the experiments LLC samples of 40% and 50% concentration were used. Control of status of the experimental samples was performed using *Biolar* polarizing interference microscope of 1400 times magnification. The light source used was a mercury lamp of 200 *Watts* capacity.

There are various methods for measuring the *Hall emf*. One of the common methods is the compensation probe method, the schematic circuit diagram of which is shown in Figure 1 [11, 12]. When measured by the compensation method that excludes the effect of contact transition resistance on the measurement accuracy.

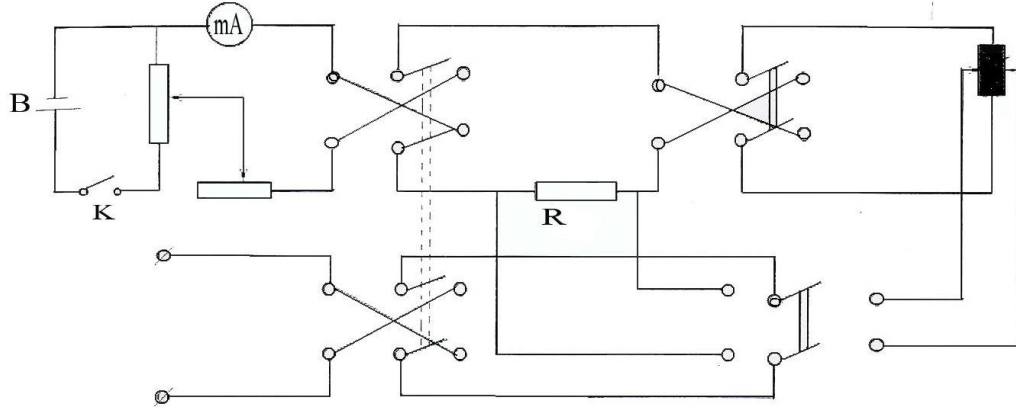

**Figure 1.** Schematic diagram of the device for measuring the *Hall effect*.

In a sample of a rectangular parallelepiped type whose length must be greater than the width of at least 3 times, as shown in Figure 1, contacts are soldered and are attached to the cell made of a nonconductive material. The contact resistance is provided by the junctions of tin obtained by melting. Frontal contacts are used to provide current through the sample, and the surface contacts – to measure the *Hall emf*.

The cell filled with the sample is placed in a magnetic field so that the magnetic induction lines are perpendicular to the current lines. The electromagnet is powered by DC source. Calibration of the magnetic field is carried out using a measuring device *E11-3*.

In addition to the difference of the Hall potentials, other *emf* are also formed, and they do not change sign in the case of changing the direction to the opposite of the constant magnetic field direction, which means that in this case we have the following relations:

$$U_1 = U_x + U_{\text{add}} \quad (1)$$

in the case of opposite direction,

$$U_2 = -U_x + U_{\text{add}} \quad (2)$$

from which we obtain

$$U_x = (U_1 - U_2)/2, \quad (3)$$

where  $U_{1,2}$  – *emf* actually measured,  $U_{\text{add}}$  – additional *emf* caused by all other phenomena,  $U_x$  – Hall potential.

Changing the direction of the magnetic field can be done in two ways:

1. Changing the direction of the electromagnet power supply.

2. Rotating the sample at  $180^{\circ}$ .

Both methods have their advantages and disadvantages. In the first case, you must strive to maintain the same value of the magnetic field  $H$ , which is practically impossible. This is due both to the measurement accuracy of the measuring device and its general scheme. In the second case, the error is due to the inability to precisely positioning the sample parallel to the poles of an electromagnet. Consequently the angle of the magnetic induction vector in relation to the previous axis is changed.

In this research we change the direction of the current, which feeds the electromagnet.

## Experimental Results and Discussions

Prior to placing the sample in crossed electric and magnetic fields, it was studied by polarizing interference optical microscope to determine the distribution of the micelles before applying the field (Figure 2).

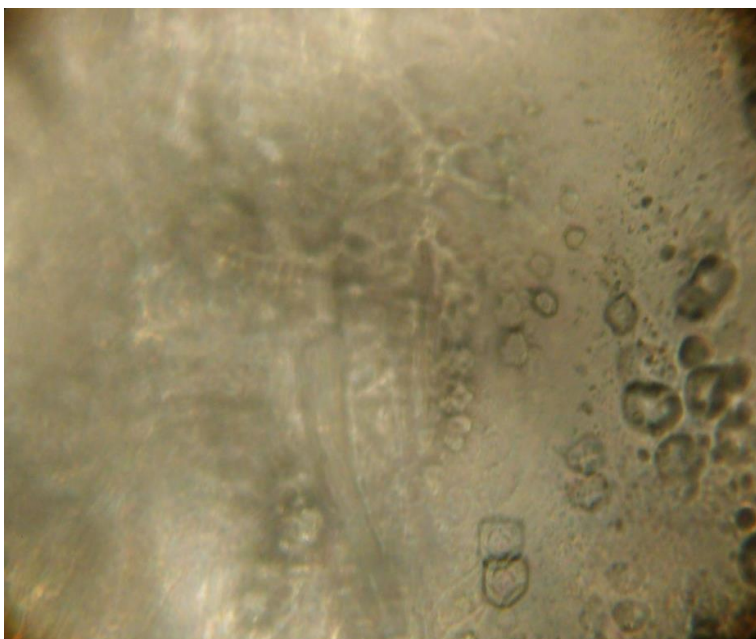

**Figure 2.** Distribution of micelles prior to the application of the field.

Further the sample is attached to a special probe and placed in the device for measuring the characteristics of the *Hall effect*, applying simultaneously electric and magnetic fields perpendicular directed to each other.

The results obtained for 40% of the amphiphile - water and for 50% amphiphile - water systems are given in Tables 1, 2.

**Table 1.** Liquid crystal system: 40% pentadecyl sulphate - water.

	I = 0.38 mA	I = 10 mA	I = 78 mA
--	-------------	-----------	-----------

	B = 1Tesla	B = 1Tesla	B = 1Tesla
$U_{res}$	40 mV	66 - 68 mV	80 mV
after 24h $U_{res}$	-20 mV	-30 mV	-38 mV
after 24h $U_{res}$	+5 mV	+10 mV	+12 mV

**Table 2.** Liquid crystal system: 50% pentadecyl sulphate - water.

I = 0.38mA B = 1Tesla	I = 10mA B = 1Tesla
$U_{res}$	66.1 mV
after 48h $U_{res}$	+14 mV
after 12h $U_{res}$	-4 mV
after 12h $U_{res}$	+4 mV

As seen from Tables 1, 2 at a constant value of magnetic induction (B), the residual Hall potential ( $U_{res}$ ) increases with current (I) increase, although for a sample with a high concentration the residual potential is smaller than in the case of a low concentration. This can be explained by an increase in resistance of the medium with respect to the micelle.

In contrast to the well-known *Hall effect*, the sample exhibits a residual memory after removing the effects of electric and magnetic fields, and after 24 hours the residual stress, decreasing in the sample face, changes the sign of the potential difference. Over the next 24 hours the charge sign changes again and hence the Hall potential continues to decrease. In semiconductors sharp nulling of the Hall potential indicates that in this case the carriers are free electrons, which have no inertia due to their small mass. Another picture is observed for micelles, which having a relatively large mass have a relatively large inertia and, therefore, charged micelles appear successively at one or the other face of the cell. For this reason, there is an accumulation of mass of the amphiphilic substance at electrodes of the cell, which was also observed using an optical microscope (Figure 3).



**Figure 3.** Sample image obtained using an optical microscope after removal the external exposure.

## **Conclusions**

Based on the experimental data, the following conclusions can be put forward:

1. The Hall potential for the sample with a LLC 100 times is greater than in semiconductors.
2. After removing the influence of the electric and magnetic fields, the Hall potential is remained intact.
3. The resting Hall potential decreasing over time changes its sign.
4. In the sample parallel to the increase of concentration of the amphiphilic substance the Hall potential decreases.

The results obtained can be used to manufacture more sensitive sensors, as well as for studying topogram of magnetic field. With the help of this phenomenon the strange behavior of biological objects in magnetic fields can be explained as well, since the structure of biological objects, mostly consists of LLCs.

## References

- [1]. N.S. Averkiev and M.I. Dyakonov, *Fiz. Tekh. Poluprovodn*, **17**, 629 (1983) [*Sov. Phys. Semicond.* **17**, 393 (1983)].
- [2]. Richard J. Matyi and Mark A. Reed, “Quantization of the Hall effect in a 3-dimensional quasiperiodic system”, *Superlattices and Microstructures*, **3**, 535–538 (1987).
- [3]. D.W. Preston and E.R. Dietz, “Excellent discussion of the Hall effect in semiconductors”, *The Art of Experimental Physics*, John Wiley & Sons, 303–315 (1991).
- [4]. J. Weis and K. von Klitzing, “Metrology and microscopic picture of the integer quantum Hall effect”, *Phil. Trans. R. Soc. A*, **369**, 3954–3974 (2011).
- [5]. Yang Ren, Masaaki Yamada, Hantao Ji, Seth Dorfman, Stefan P. Gerhardt, and Russel Kulsrud, “Experimental study of the Hall effect and electron diffusion region during magnetic reconnection in a laboratory plasma”, *Physics of Plasmas*, **15**, 1–20 (2008).
- [6]. N.P. Stern, S. Ghosh, G. Xiang, M. Zhu, N. Samarth, and D.D. Awschalom, “Current-Induced Polarization and the Spin Hall effect at Room Temperature”, *Phys. Rev. Lett.*, **97**, 126603 (2006).
- [7]. K.S. Novoselov, Z. Jiang, Y. Zhang, S.V. Morozov, H. L. Stormer, U. Zeitler, J.C. Maan, G.S. Boebinger, P. Kim, A.K. Geim, “Room-Temperature Quantum Hall Effect in Graphene”, *Science*, **315** 1370–1379 (2007).
- [8]. C. R. Dean, L. Wang, P. Maher, C. Forsythe, F. Ghahari, Y. Gao, J. Katoch, M. Ishigami, “Hofstadter’s butterfly and the fractal quantum Hall effect in moiré superlattices”, *Physica B* **169**, 363–367 (1991).
- [9]. Badalyan G.G., Minasyants M.H., Shahinyan A.A., “Effect of electric and magnetic fields on the current-voltage characteristics of the lyotropic liquid crystal”, *Crystallography*, **42**, 502–506 (1997).
- [10]. Badalyan G.G., Shahinyan A.A., Minasyants M.H., “Influence of static electric fields on the structure of a lyotropic liquid crystal”, *Izvestiya Akademii Nauk Arm. SSR, Physics*, **23**, 72–77 (1989).
- [11]. Debanjan Bhowmik, Long You & Sayeef Salahuddin, “Spin Hall effect clocking of nanomagnetic logic without a magnetic field”, *Nature Nanotechnology* **9**, 59–63 (2014).
- [12]. Luqiao Liu, Ching-Tzu Chen & J. Z. Sun, Spin, “Hall effect tunnelling spectroscopy”, *Nature Physics*, **10**, 561–566 (2014).

HAMLET G. BADALYAN

Yerevan State University,  
Department of General Physics,  
1 Alex Manoogian St., Yerevan 0025  
Armenia

Phone: +374-77-288515

Fax: +374-60-612512

E-mail: [hbadal@ysu.am](mailto:hbadal@ysu.am)

STEPAN M. YAYLOYAN

Department of General Physics,  
1 Alex Manoogian St., Yerevan 0025  
Armenia

Phone: +374-91-417644

Fax: +374-60-612512

E-mail: [syayloya@aua.am](mailto:syayloya@aua.am)